

LMPX-100

Digital Lighting Management

**PIR Corner Mount
Occupancy Sensor
Dense Lens**

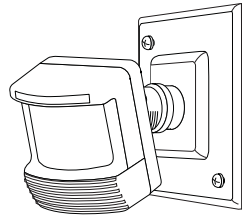

THIS UNIT IS PRE-SET FOR PLUG n' GO™ OPERATION, ADJUSTMENT IS OPTIONAL.

For full operational details, adjustment and more features of the product, see the DLM System Installation Guide provided with the LMRC-102 and also available at www.wattstopper.com

INSTALLATION SHALL BE IN ACCORDANCE WITH ALL APPLICABLE REGULATIONS, LOCAL AND NEC CODES.

Intended for Listed Class 2 DLM Devices.

For Class 2 DLM devices - To be connected to a Class 2 power source only.

For Class 2 Device Wiring Only – Do Not Reclassify and Install as Class 1, or Power and Lighting Wiring.

Wire connections shall be rated suitable for the wire size (lead and building wiring) employed.

- Voltage: 24VDC
- Current Consumption:..... 7mA
- Power Supply:..... Watt Stopper/Legrand Room Controllers
- Connection to the DLM Local Network RJ-45 plug
- DLM Local Network Characteristics:
 Provides low voltage power over Cat 5e cable (LMRJ).
 Supports up to 24 communicating devices, including 4 LMRC-10x or LMPL-101 max per each DLM Local Network.
 Free topology up to 1,000ft of low voltage cable.
- Environment For Indoor Use Only
- Operating Temperature32° to 131°F (0° to 55°C)
- Storage Temperature..... 23° to 176°F (-5° to 80°C)
- Relative Humidity.....5 to 95% (non condensing)
- Patent Pending

SENSOR PLACEMENT

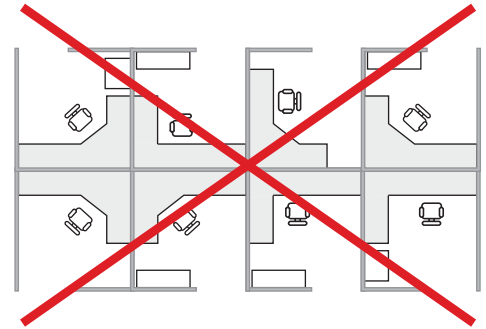
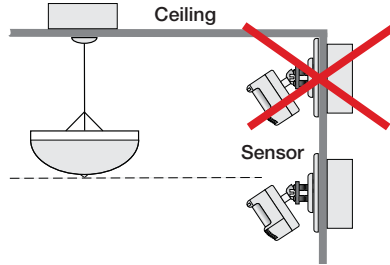
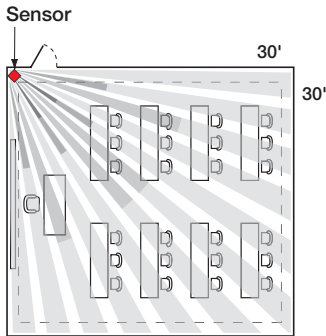

COVERAGE PATTERN

Coverages shown are maximum and represent half-step walking motion.

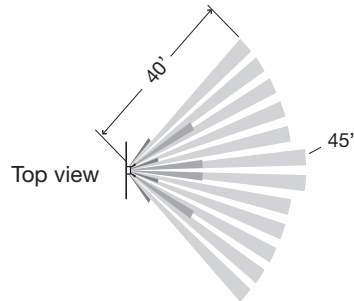
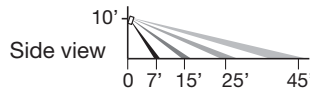

CONNECTIVITY

The illustrations below show examples of free-topology wiring. The LMPX-100 communicates to all other Digital Lighting Management devices connected to the low voltage DLM Local Network, regardless of their position on the DLM Local Network.

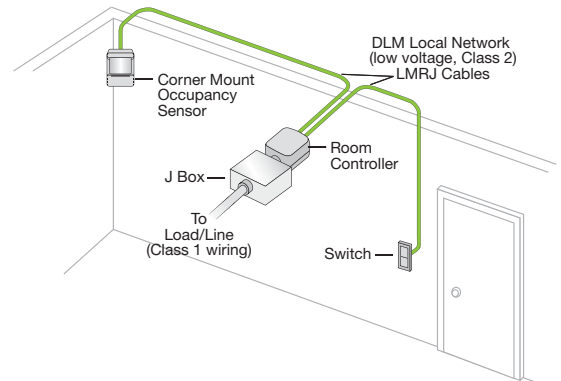
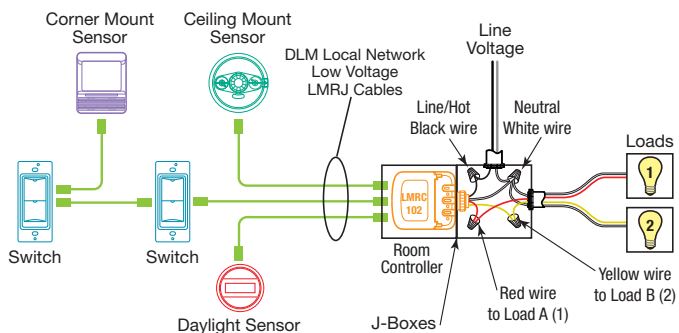

MOUNTING

WARNING: Do Not Install To Cover a Junction Box Having Class 1, 3 or Power and Lighting Circuits.

through ceiling tile

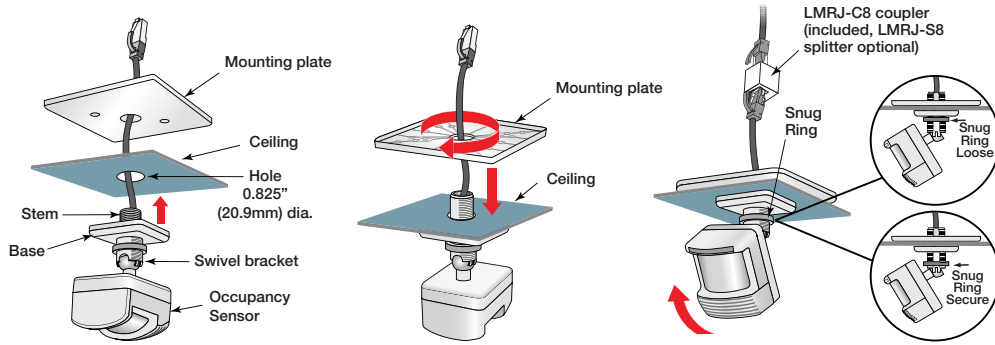

through wall

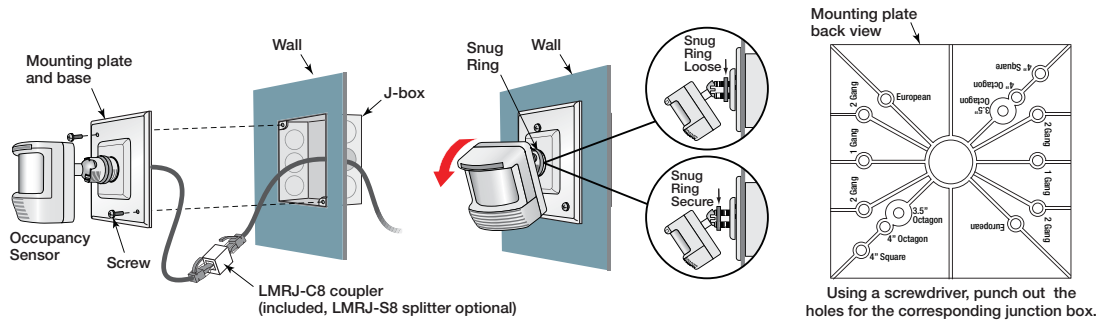



FACTORY PRE-SET OPERATION

Sensor Parameters

T-DELAY	Time Delay	20 minutes
	Passive Infrared Sensitivity	90%
W-T	Walk Through	OFF

Load Parameters

	 Load 1	 Loads 2-8 or more**	 Plug Load
ON Mode Operation*	AUTO-ON	MANUAL-ON if switch is used. AUTO-ON if switch is not used.	AUTO-ON
Blink Warning	OFF	OFF	OFF
Daylighting	ON	OFF	OFF

* Auto-OFF is enabled according to the sensor Time Delay when a sensor is bound to the load, regardless of whether the load was turned on automatically with occupancy or manually using a switch.

** Max 8 loads using LMRC-100 series room controllers.

TROUBLESHOOTING

Loads do not operate as expected.



WARNING: TO CONNECT A COMPUTER TO THE DLM LOCAL NETWORK USE THE LMCI-100. NEVER CONNECT THE DLM LOCAL NETWORK TO AN ETHERNET PORT - DOING SO MAY DAMAGE COMPUTERS AND OTHER CONNECTED EQUIPMENT.

LEDs don't light, display is off	<ol style="list-style-type: none"> Check to see that the the sensor is connected to the DLM local Network. Check for 24VDC input to the sensor: Plug in a different DLM device at the sensor location. If the device does not power up, 24VDC is not present. <ul style="list-style-type: none"> Check the high voltage connections to the room controller. If high voltage connections are good and high voltage is present, recheck DLM local Network connections between the sensor and the room controller.
The wrong lights are controlled	<ol style="list-style-type: none"> Configure the sensor to control the desired lights using the Push n' Learn adjustment procedure.
LEDs turn ON and OFF but load doesn't switch	<ol style="list-style-type: none"> Make sure device is not in PnL. Check load connections to room controller.