

LMDX-100 Digital Dual Technology Corner Mount Occupancy Sensor

Combines passive infrared and ultrasonic technologies for most comprehensive coverage

Component of Digital Lighting Management integrated control system

Quick access to Push n' Learn for system personalization



Digital sensor with LCD display and programming pushbuttons behind snap-down cover

IR transceiver for wireless configuration and remote control

Compact 2.4" x 3" sensor mounts easily on a wall or ceiling

PROJECT

LOCATION/TYPE

Product Overview

Description

The LMDX-100 Digital Dual Technology Corner Mount Occupancy Sensor uses both passive infrared (PIR) and ultrasonic technologies to achieve precise occupancy sensing for energy-efficient control of lighting and plug loads. It is a digital sensor, and is part of a WattStopper Digital Lighting Management (DLM) system.

Operation

The LMDX-100 operates on Class 2 power supplied to a DLM local network by one or more DLM room controllers. It works with the room controller(s) to turn loads on and off based on occupancy. Default operation is established by Plug n' Go, which automatically configures system components to maximize energy savings. Initially, all occupancy sensors control all loads on the same local network. Each LMDX-100 may be assigned to a specific load; load assignments and load parameters may be changed using Push n' Learn. The LMDX-100 may be reconfigured either using the pushbuttons and an LCD screen conveniently located behind a snap-down cover on the front of the sensor, or with a wireless configuration tool.

Digital Settings and IR Communications

The LMDX-100 includes a unique, easy-to-access, LCD screen that displays sensor parameters and simplifies changing those parameters. Time delay and sensitivity can be precisely adjusted. Additionally, walk through mode can be activated and detection and retrigger technologies may be changed. Changes are made at the sensor with easy-to-use pushbuttons, or via a wireless configuration tool that communicates with the sensor using a bi-directional infrared (IR) signal. The LMDX-100 IR transceiver allows wireless system operation in addition to configuration. The LCD display also facilitates system personalization, showing load information when in Push n' Learn mode.

Applications

The LMDX-100 senses both large and small motions and is recommended for spaces including conference rooms, private offices, classrooms and computer rooms where using just one detection technology could result in false triggers. Mounted at ten feet, the LMDX-100 can detect walking motion throughout an area of approximately 2,000 square feet, and desktop motion for up to 1,000 square feet.

Features

- Plug n' Go™ automatic configuration for quick installation and maximum energy savings
- Push n' Learn™ functionality for customization without the need for tools or a PC
- Digital Lighting Management components plug together on a free-topology Category 5e DLM local network
- Infrared (IR) transceiver for wireless configuration and control
- Ultrasonic diffusion technology spreads coverage to a wider area (patented); 40KHz signal
- Detection Signature Processing eliminates false triggers and provides immunity to RFI and EMI
- Sensor coverage tested to NEMA Guide Publication WD 7-2000
- RoHS compliant
- Qualifies for ARRA-funded public works projects



Specifications

- Input voltage: 24VDC from DLM network
- Current consumption: 20mA
- DLM local network connection: 1 RJ45 port via RJ45 plug and coupler (included)
- LCD display and pushbuttons for setting sensor and system parameters
- Infrared (IR) transceiver
- Ultrasonic frequency: 40 kHz
- Operating conditions: for indoor use only; 32-104°F (0-40°C); 5-95% RH, non-condensing
- UL and cUL listed
- FCC part 15 compliant
- Five year warranty

Controls & Indicators

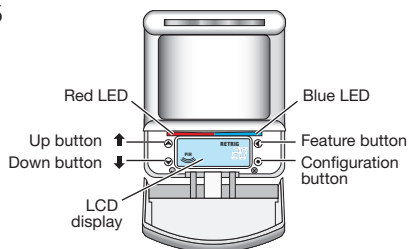

Sensor Parameter	Available Options	Default Setting
Time Delay	1-30 min. (1min. increments) /Override	20 minutes
Walk Thru	On/Off	Off
PIR Sensitivity	10-100% (10% increments)/Off	90%
Ultrasonic Sensitivity	10-100% (10% increments)/Off	70%
Test Mode	Activate	Off
Detection Technology	Ultrasonic/PIR/Both/Neither	Both
Retrigger Technology	Ultrasonic/PIR/Both/Neither	Either

Dimensions & Mounting

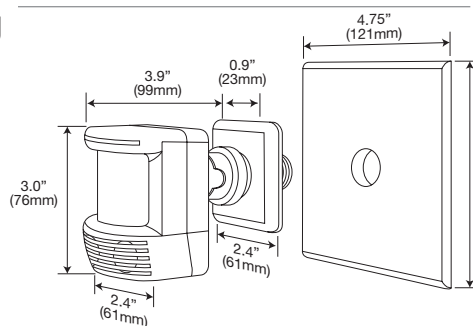

Wall and Ceiling Mounting Options

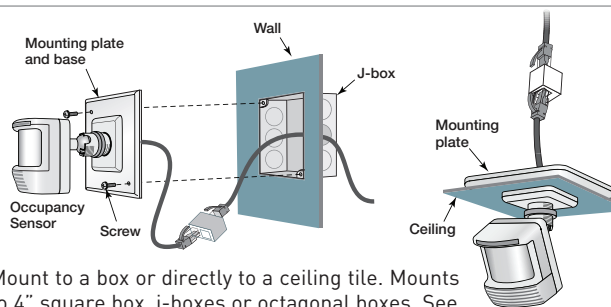

Mount to a box or directly to a ceiling tile. Mounts to 4" square box, j-boxes or octagonal boxes. See installation instructions for more details.

Coverage & Placement

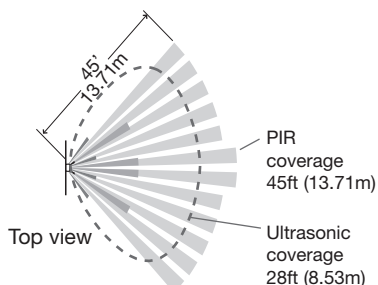

Top view
PIR coverage 45ft (13.71m)
Ultrasonic coverage 28ft (8.53m)

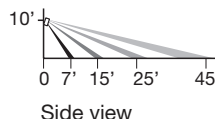

Sensor Placement

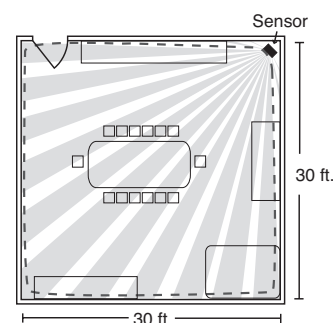

Wiring

Sample Connection Diagram

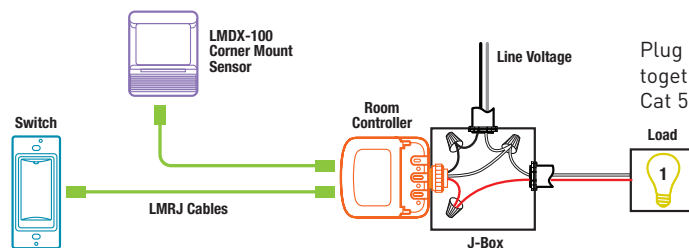

Plug DLM local network components together in any configuration using Cat 5e cables with RJ45 connectors.

Ordering Information

Catalog No.	Color	Description
<input type="checkbox"/> LMDX-100	White	Digital Dual Technology Corner Mount Occupancy Sensor
<input type="checkbox"/> LMDX-100-U	White	Digital Dual Technology Corner Mount Occupancy Sensor, ARRA-compliant