

# DT-205

version 2

Dual Technology • Low Voltage  
Occupancy Sensor



# Installation Instructions

## Specifications

Voltage .....	18-28VDC/VAC
Current Consumption .....	35mA
Power Supply .....	WattStopper Power Packs
Operating Temperature.....	32° to 131°F (0° to 55°C)
Time Delay Adjustment.....	5 to 30 minutes
Walk-Through Mode ...	3 minutes if no activity after 30 sec.
Test Mode .5 sec. upon	initial power-up or DIP switch reset
PIR Coverage (Typical) .....	1000 ft <sup>2</sup>
Sensitivity Adjustment	Automatic or Low (DIP switch setting)
Ultrasonic Coverage (Typical) .....	800-1200 ft <sup>2</sup>
Sensitivity Adjustment .....	Minimum to Maximum (trimpot)
Frequency .....	40kHz

U.S. Patent: 5,189,393

**WattStopper®**

Santa Clara, CA 95050

## UNIT DESCRIPTION

The WattStopper DT-205 Dual Technology occupancy sensors combine advanced passive infrared (PIR) and ultrasonic technologies into one unit. The combination of these technologies helps to eliminate false triggering problems even in difficult applications.

The DT-205 turns lighting systems on and off based on occupancy. The DT-205 offers numerous operating modes that can be combined to create the ideal custom control. The sensors can be configured to turn lighting on, and hold it on as long as either or both technologies detect occupancy. After no movement is detected for the duration of the time delay (5 to 30 minutes) the lights are switched off. A "walk-through" mode can turn lights off after only 3 minutes, if no activity is detected after 30 seconds of an occupancy detection.

The DT-205 operates on 24VDC supplied by WattStopper Power Packs.

## COVERAGE PATTERN

The DT-205 provides an elliptical coverage pattern. The coverage shown represents walking motion at a mounting height of 10 feet. For building spaces with lower levels of activity or with obstacles and barriers, coverage size may decrease.

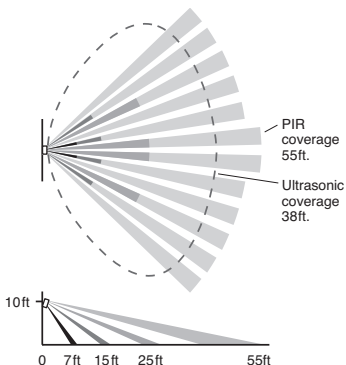

### Dense Wide Angle Lens

up to 2000 sq ft for walking motion  
up to 1000 sq ft for desktop motion

[Drawings not to scale.]

**Call 800.879.8585 for Technical Support**

## PLACEMENT GUIDELINES

Depending upon obstacles such as furniture or partitions, the area of coverage may be less or more than the sensing distances shown in the coverage pattern. This must be considered when planning the number of sensors and their placement. It is also recommended to place the sensor 4 to 6 feet away from air supply ducts.

The DT-205 is designed for a ceiling height of about 8-10 feet. Mounting above or below this range will significantly affect the coverage patterns. As a general rule, each occupant should be able to clearly view the sensor.

**Masking the PIR Lens:** Opaque adhesive tape is supplied so that sections of the PIR lens can be masked. This restricts the sensor's view and allows you to eliminate PIR coverage in unwanted areas such as hallways outside of the desired coverage area. Since masking removes bands of coverage, remember to take this into account when troubleshooting coverage problems. The Ultrasonic coverage cannot be masked, but you can adjust its sensitivity to reduce the coverage area.

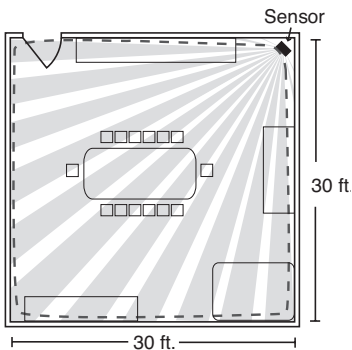

One sensor, conference room

**Drawings not to scale.**

**Visit our website for FAQs: [www.wattstopper.com](http://www.wattstopper.com)**

## WIRING DIRECTIONS



### TURN POWER OFF AT THE CIRCUIT BREAKER BEFORE INSTALLING POWER PACKS OR SENSORS.

Each WattStopper B series power pack can supply power for up to 2 DT-205 sensors. Each WattStopper BZ series power pack can supply power for 3 DT-205 sensors. When using more sensors than this, multiple power packs are required.

Refer to the wiring diagram on the next page for the following procedures:

Connect the **LOW VOLTAGE**:

- RED wire (+24VDC) from power pack to the **red** wire on the sensor.
- BLACK wire (Return) from power pack to the **black** wire on the sensor.

Wiring a **SINGLE LIGHTING LOAD CONTROLLED BY OCCUPANCY**—connect:

- BLUE wire from power pack to the **blue** wire on the sensor.

To add a **MOMENTARY MANUAL SWITCH** such as the LVS-1 Momentary Toggle Switch, to the above applications—connect:

- Wire from one side of switch to the **gray** wire on sensor.
- Wire from other side of switch to the **black** wire on sensor.

Call 800.879.8585 for Technical Support

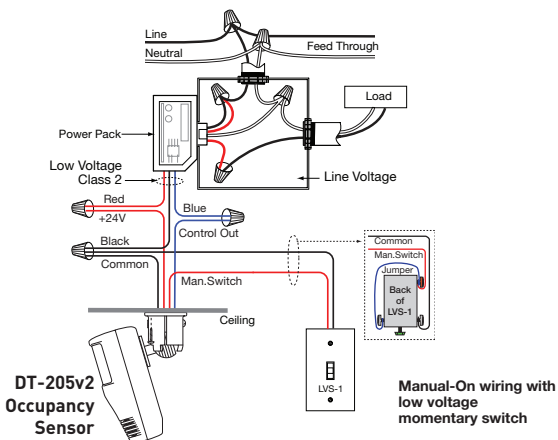
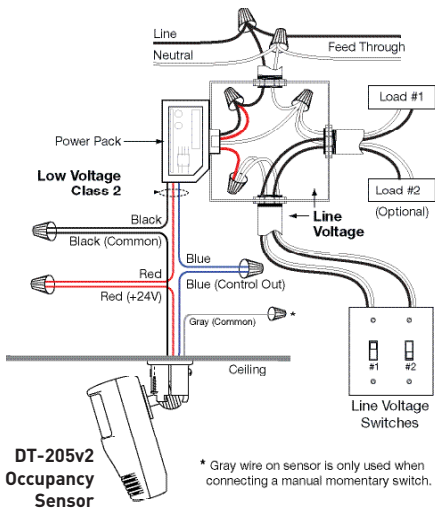

## MOUNTING THE SENSOR

The DT-205 sensors can be mounted to walls or ceilings with the supplied swivel bracket, and the supplied junction box cover plate if necessary (see figure B). Mounting at fixture height is most effective.

**Ceiling:** It is best to leave approximately six inches between the sensor and the wall so that the Tightening Screw can be easily accessed. Orient the Base Bracket's Half-Circle Notch in the direction that the sensor will point.

**Wall:** Orient the Base Bracket's Half-Circle Notch, up.

1. Mount the Base Bracket to the mounting surface with screws.
2. At the center of the Base Bracket, drill a hole in the ceiling or wall (unless mounting to a junction box) large enough to thread the sensor's wires through.
3. Guide the sensor's wires into the Base Bracket and through the hole in the ceiling or wall.
4. Connect the sensor to the Base Bracket by angling the Post Bracket so that it is in line with the half circle notch, as illustrated in figure A. Push the ball into the Base Bracket opening until it snaps into place, being careful not to pinch the wires. The brackets can be easily connected or disconnected using this orientation.
5. Insert the Tightening Screw and Nut into the Base Bracket as illustrated.
6. Use the Reference Surface Angle to adjust the sensor for optimum coverage. When mounted at ten feet, the Reference Surface Angle should be parallel to the wall or the vertical (see figure C). (As the mounting height decreases, the sensor will be tilted up slightly; as the mounting height increases, the sensor will be tilted down slightly).
7. Tighten the Tightening Screw.

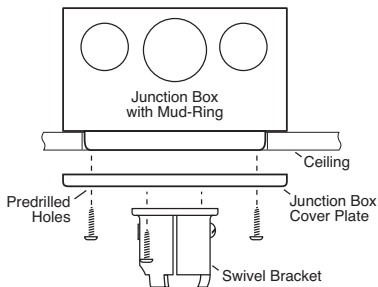
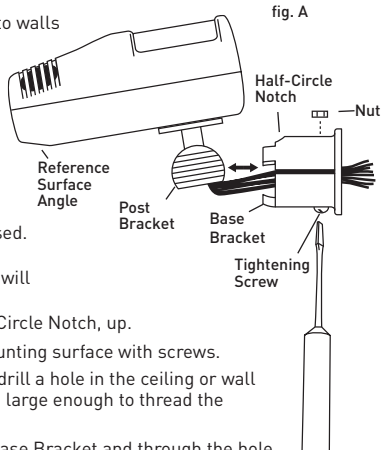

### Junction box cover plate installation

WattStopper recommends using a 3.0" mudring with a 4" octagonal box

## Sensor Angle Adjustment

While watching the LEDs for flashes (Red LED indicates activation from the PIR sensor; Green LED indicates activation from the ultrasonic sensor), have a person walk back and forth at the far end of the space. Increase or decrease mounting angle as needed until the desired coverage is achieved.

Tighten the Tightening Screw to hold this position.

### Ceiling Mount

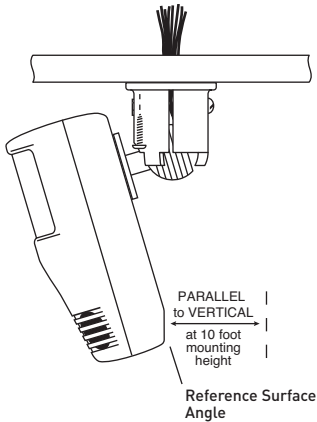

### Wall Mount

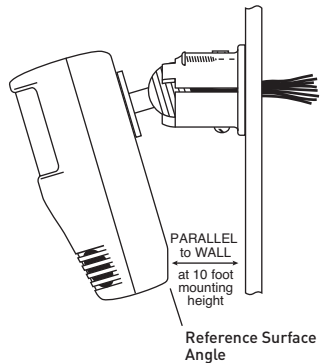

fig. C

## Override

To override all sensor functions, set the Ultrasonic Sensitivity trimpot to the fully counterclockwise (Override) position. This bypasses the occupancy control functions of the sensor, but still allows the lights to be manually controlled with a light switch, if one is installed.

## SENSOR ADJUSTMENT

The sensors are factory preset to allow for quick installation in most applications. Verification of proper wiring or coverage, or customizing the sensor's settings can be done using the following procedures. To make adjustments, open the Front Cover with a small screwdriver.

**There is a 30 second warm-up period when power is first applied.**

Before making adjustments, make sure the office furniture is installed, lighting circuits are turned on, and the HVAC systems are in the overridden/on position. VAV systems should be set to their highest airflow. Set the Logic Configuration and Time Delay to the desired settings. See "Logic Configuration Chart", next page.

### To Test Occupancy Sensors

1. Ensure the PIR and Ultrasonic Activity LEDs are enabled (DIP switch 7 ON) and PIR Sensitivity is set to MAX (DIP switch #8 ON).
2. Ensure the Time Delay is set for **Test Mode\*** using the "5 seconds/Auto" setting. (DIP switches 4, 5, & 6 are OFF).
3. Ensure that the Ultrasonic Sensitivity trimpot is set to about 90%, clockwise.
4. Remain still. The red and green LEDs should not flash. The lights should turn off after 5 seconds. (If not, see "Troubleshooting.")
5. Move about the coverage area. The lights should come on. Adjust the Ultrasonic Sensitivity as necessary to provide the desired coverage (Green LED indicates activation from the ultrasonic sensor).

When testing and adjustment is complete, reset DIP Switches to the desired settings, and replace the cover on the sensor.

- \* If you need to invoke the **Test Mode** and the DIP switches are already set for 5 seconds/Auto, toggle DIP switch #5 ON then back to the OFF position. This provides a 5 minute test period. During the test period, the Time Delay is only 5 seconds.

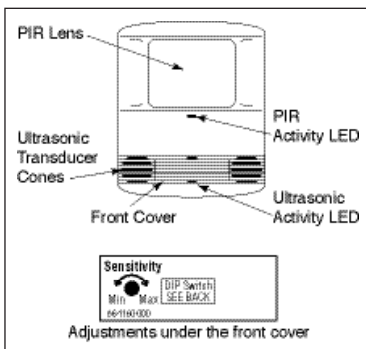

**Call 800.879.8585 for Technical Support**

## OCCUPANCY LOGIC

The DT-205 has 8 logic configurations for occupancy triggers, set with DIP switches 1, 2 & 3. Determine the appropriate Occupancy Logic Option using the Trigger matrix, then set the DIP switches accordingly.

**Initial Occupancy:** The method that activates a change from "Standby" (area unoccupied and loads are off) to "Occupied" (area occupied and loads are on).

- **Both** requires detection by PIR **and** Ultrasonic.
- **Either** requires detection by only one technology.
- **PIR** requires detection by the PIR.
- **Ultra** requires detection by the Ultrasonic.
- **Man.** requires activation of the Manual Switch. (See Manual On functions" for further information.)

**Maintain Occupancy:** The method indicating that the area is still occupied and the lights should remain on.

**Re-trigger:** After the time delay elapses and the lights turn off, detection by the selected technology within the number of seconds indicated turns the lights back on.

### To turn off a technology:

- Option 4 turns off the Ultrasonic detection
- Option 5 turns off the PIR detection

### Time Delay: Switches 4, 5, 6

The sensor will hold the lights on as long as occupancy is detected. The time delay countdown starts when no motion is detected. After no motion is detected for the length of the time delay, the sensor will turn the lights off. The sensor can select the time delay using Auto, or you can select a fixed time delay.

- "Auto" records occupancy patterns and uses this history to choose an optimal time delay from 5 to 30 minutes. Recording starts immediately and optimization is continuous as history is collected.

 Walk-through mode turns the lights off three minutes after the area is initially occupied, if no motion is detected after the first 30 seconds. If motion continues beyond the first 30 seconds, the selected time delay applies.

## Logic Configuration Chart





	Trigger	Initial Occupancy	Maintain Occupancy	Re-trigger (seconds duration)
Occupancy Logic	Standard	Both	Either	Either(5)
	Option 1	Either	Either	Either(5)
	Option 2	PIR	Either	Either(5)
	Option 3	Both	Both	Both(5)
	Option 4	PIR	PIR	PIR(5)
	Option 5	Ultra	Ultra	Ultra(5)
	Option 6	Man.	Either	Either(30)
Option 7	Man.	Both	Both(30)	

◀ = Factory Setting

● = ON

- = OFF

		Switch#		
Logic		1	2	3
Occupancy	Standard	-	-	-
	Option 1	●	-	-
	Option 2	-	●	-
	Option 3	●	●	-
	Option 4	-	-	●
	Option 5	●	-	●
	Option 6	-	●	●
Option 7	●	●	●	

Time Delay	4	5	6
5 sec/Auto 	-	-	-
5 minutes	-	-	●
10 min. 	-	●	-
10 minutes	-	●	●
15 min. 	●	-	-
15 minutes	●	-	●
20 minutes	●	●	-
30 min. 	●	●	●

 = walk-through mode

LEDs	7
Disabled	-
Enabled	●

PIR Sensitivity	8
Minimum	-
Max./Auto	●

## LEDs

When enabled, the red PIR and green Ultrasonic Activity LEDs on the sensor will light when the associated technology detects motion.

## PIR Sensitivity

- Minimum forces a reduced detection range for the PIR.
- Max./Auto causes the DT-205 to monitor the controlled environment and automatically select the maximum sensitivity that will provide reliable operation without false detection. This setting is constantly updated.

## MANUAL ON FUNCTION

The Manual ON function is facilitated by installing a momentary switch such as the WattStopper LVS-1 Momentary Toggle Switch, or RS2-3 Low Voltage Momentary Switch. This switch connects to the sensor as shown in the wiring diagram. Each time the switch is pressed, the load changes state. The sensor's operation as related to the manually operated switch is determined by DIP switch settings for Occupancy Logic.

**Manual Mode** (Trigger Option 7 or 8): In this mode, the switch **is required** to turn on the load. The sensor is then used to keep the load on, based on occupant activity. After the time delay ends the manual switch must be used to turn the load on, if there is no movement detected within the 30 second re-trigger period.

**Automatic ON Mode** (any Trigger Option except 6 or 7): These options use occupancy triggers as well as switch activation to turn the load ON. A manual switch provides the following additional functionality:

- a. The load can be turned ON by manual switch activation and it stays on according to the occupancy logic setting. The sensor time delay operates as programmed. When the load turns OFF due to lack of occupancy detection, the load can be turned ON again by occupancy detection or switch activation.
- b. Activating the manual switch while the load is ON turns the load OFF.
  - When the load is turned OFF manually, as long as the sensor continues to detect occupancy the load stays OFF. Five minutes after the last occupancy detection, the lights stay off and the sensor reverts to the automatic-on mode.
  - When the load is turned OFF manually, pressing the switch again turns the load ON and the sensor reverts to the automatic-on mode.
  - Once the sensor returns to automatic-on mode, either the switch or occupancy detection can turn the load ON.

**Call 800.879.8585 for Technical Support**

## TROUBLESHOOTING



**CAUTION**



**TURN POWER OFF AT THE CIRCUIT BREAKER  
BEFORE WORKING WITH OR NEAR HIGH VOLTAGE.**

**Lights do not turn on with occupancy, and the following condition exists:**

- Both LEDs do not flash:
  1. Check that the circuit breaker has been turned back on.
  2. Check all sensor and power pack wire connections.
  3. Check for 24V input to the sensor.
    - If 24V is present, replace the sensor.
    - If 24V is not present, check that high voltage is present to power pack. If it is, replace power pack.
- Red LED does not flash:

When power is initially applied to the sensor, there is a warm-up period of up to 30 seconds before the red LED is active.

1. Make sure that PIR Sensitivity is set to 100% (DIP switch #8 set to on).
  2. Check to see if DIP switches are set to option 5.
  3. If it still does not flash, call 800.879.8585 for Technical Support.
- Green LED does not flash:
    1. The Ultrasonic Sensitivity setting may need to be increased.
    2. Check to see if DIP switches are set to option 4.
  - Both LEDs flash:
    1. Check all sensor and power pack wire connections.
    2. Check for 24VDC at the power pack's blue wire connection to sensor while sensor is activated. If there is no voltage, replace the sensor. If there is voltage, replace the power pack.

**Lights do not turn off automatically:**

1. One or both of the sensor technologies (PIR or ultrasonic) may be experiencing activations from outside the controlled area or from some type of interference (see "Unwanted Sensor Activations" below).
2. Check all sensor and power pack wire connections.
3. Disconnect power pack's blue wire:

If the lights do not turn off, replace power pack. Reconnect blue wire.

If the lights turn off, the problem may be in the sensor—to check:

Reconnect the blue wire.

Turn sensitivity and time delay to minimum and allow the sensor to time out.

If the lights turn off, the sensor is working properly (see number 1, above, and "Sensor Adjustment" for readjustment of sensor).
4. If you are getting a solid green LED, check ultrasonic trimpot setting.

## Unwanted Sensor Activations (LED flashes):

1. Improper sensor location or inadequate masking causing detection outside of desired coverage area.
  2. The ultrasonic sensitivity may be too high.
  3. The PIR sensitivity may be set too high.
  4. Sensor located too close to HVAC or VAV vents with heavy air flow.
- Possible solutions
    1. Reduce the ultrasonic sensitivity as needed (see "Sensor Adjustment").
    2. Mask the lens to reduce PIR coverage (see "Masking the PIR Lens", under "Placement Guidelines").
    3. Change the logic configuration setting, see "DIP Switches."
    4. Relocate the sensor.

## ORDERING INFORMATION

Catalog #	Description
DT-200	Dual Technology Occupancy Sensor, Low Voltage w/Isolated Relay
DT-205	Dual Technology Occupancy Sensor, Low Voltage
BZ-100	Power Pack: 120/277VAC, 60Hz, 150mA with relay connected, 20A ballast/incandescent, 1HP@120/240VAC
B120E-P	Power Pack: 120VAC, 60Hz, 150mA, 20A ballast/13A incandescent
B230E-P	Power Pack: 230VAC, 50/60Hz, 150mA 20A ballast/13A incandescent
B277E-P	Power Pack: 277VAC, 60Hz, 150mA, 20A ballast
B347D-P	Power Pack: 347VAC, 60Hz, 150mA. 15A ballast
S120/277/347E-P	Auxiliary Relay Pack: 120/277VAC, 60Hz, 20A Ballast 347VAC, 60Hz, 15A Ballast

A Group brand  
**legrand**

## WARRANTY INFORMATION

WattStopper warrants its products to be free of defects in materials and workmanship for a period of five years. There are no obligations or liabilities on the part of WattStopper for consequential damages arising out of or in connection with the use or performance of this product or other indirect damages with respect to loss of property, revenue, or profit, or cost of removal, installation or reinstallation.

# WattStopper®

2800 De La Cruz Boulevard, Santa Clara, CA 95050  
Technical Support: 800.879.8585 • [www.wattstopper.com](http://www.wattstopper.com)

03412r3 10/2009

Please  
Recycle

